

MICROPILE DESIGN AND CONSTRUCTION IN LIMITED ACCESS WETLAND HABITAT

Steve Davidow, P.E., S.E., P.Eng., Quanta Subsurface, LLC
Nick Salisbury, Crux Subsurface, Inc.

ABSTRACT

This paper will discuss the use of micropiles as a specialty deep foundation solution to limited construction access challenges within the Troy Meadows wetland portion of PSE&G's 500 kV Susquehanna to Roseland Electric Reliability Project. Micropile foundations were constructed utilizing primarily helicopter access for seven 500 kV double-circuit tubular steel pole structures within the protected habitat. The successful implementation of a design-build strategy between the overhead design team and the contractor led to significant refinements in the foundation design. Value engineering efforts focused on refinement of tower loading geometry and load cases, assessment of geotechnical conditions, and reduction of foundation footprint within the wetlands environment. The paper will detail design and routing of the overhead alignment, as well as permitting restrictions and area of impact limitations. It will then provide an in-depth analysis of micropile foundation design utilizing concrete pile caps, and a detailed overview of construction methodologies.

PROJECT OVERVIEW

The Susquehanna to Roseland Electric Reliability Project (SRERP) is a new 500 kV transmission line spanning from the Susquehanna power plant in Berwick, Pennsylvania, to the Roseland switching station in Roseland, New Jersey. A portion of the alignment crosses Troy Meadows, a 3,100-acre freshwater marsh located in Morris County, New Jersey. The area has been designated as a Priority Wetland by the U.S. Environmental Protection Agency as well as a National Natural Landmark by the National Park Service. Within the protected area, the project scope included replacement of seven 230 kV lattice towers with seven new double-circuit 500 kV monopoles.

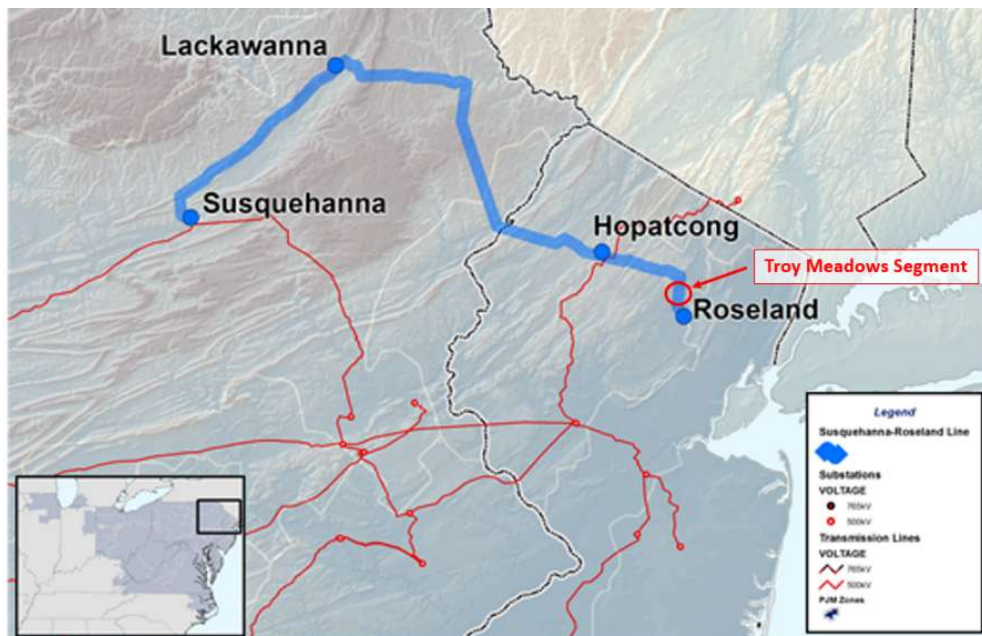

Figure 1: SRERP Alignment Map

ACCESS RESTRICTIONS

As a portion of the project siting application, detailed routing studies were completed for three potential alignment routes. The New Jersey Board of Public Utilities concurred with the owner that utilization of the existing Right-of-Way, which traversed the Troy Meadows wetland, was the preferred route for the new 500 kV SRERP.

Initial designs considered the use of a variety of conventional foundations, such as drilled shafts and driven piles. However, road construction for transportation of the necessary equipment and materials would have required extensive temporary access construction comprised predominantly of timber matting. Timber mat roads were determined to pose significant risk on two fronts; variability with changing environmental conditions, and opposition from conservation groups. Ultimately, the decision to utilize helicopter construction methods was selected to control project costs.



Figure 2: Completed Line Construction through Troy Meadows

Selecting a foundation type to meet the needs of the project was a challenging process which involved extensive input from the project designers and contractors. A comparative study was conducted to determine the foundation type that would impose the least environmental impact, and which could also be constructed entirely by helicopter. Micropile foundations were ultimately selected and the design team worked with the overhead line contractor to select a design-build micropile foundation contractor.

Micropile foundations have been employed for numerous transmission line projects requiring helicopter construction techniques. They can be installed with lighter weight equipment and materials making them conducive to light and medium lift helicopter transportation. The compact nature of the equipment also allows for a minimized area of temporary and permanent disturbance. The project team opted to employ a design-build delivery method, which they believed created the highest level of risk management and assurance of on-time completion. These were crucial elements to a project with an aggressive schedule governed by electrical outage schedules.

MICROPILE FOUNDATIONS

Micropiles have been used internationally since their development in Italy in 1952 (FHWA, 1997). In North America, the use is somewhat more recent, and is widely considered a specialty geo-construction technique, with most of the technical knowledge residing with the contractor. The industry standard for design and construction utilizing micropiles remains the FHWA State of Practice review in 1997 and updated in 2005. There have been major efforts made in the quest for a “unified” design approach, which includes publications by AASHTO and the IBC in recent years. The FHWA manual remains the most comprehensive resource available to designers to-date.

Micropiles are a small diameter (typically less than 12 inches), high-capacity drilled and grouted replacement pile. In contrast to a displacement pile, a replacement pile involves the removal of subsurface material, creating a void in which foundation elements are installed. In the transmission industry, most foundation designs employ composite micropiles reinforced with a solid threaded bar and steel casing. They are constructed by drilling a borehole through overburden material and into a bearing stratum, placing reinforcement, and grouting. They are capable of resisting axial tension and compression with applied lateral load. Micropiles have a cased upper section, composed of steel tubes, and an uncased lower bond section, which develops friction with the surrounding bearing stratum. The cased section interacts with the surrounding soil or rock to provide lateral capacity to the foundation. The piles are also reinforced with a high-capacity threaded steel bar, which extends from the top of the pile through the lower bond section, transferring axial force through friction with the grout and ground. The pile group works in tension and compression to resist overturning as shown in Figure 3.

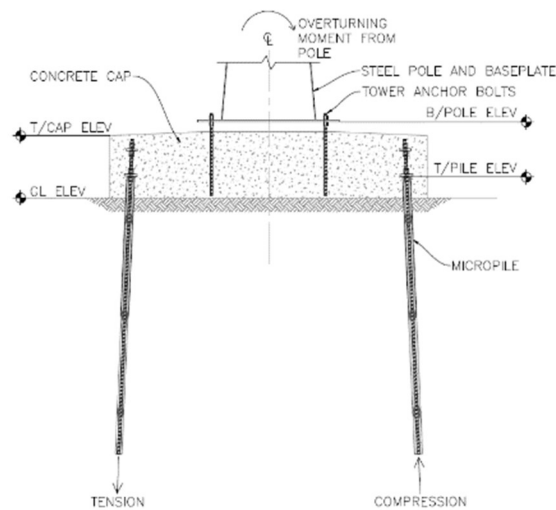

Figure 3: Micropile Tension and Compression

Micropiles are particularly advantageous to projects with one or more significant geological, structural, logistical, environmental, access or performance challenge. They are an especially favorable option where:

- The subsurface conditions are “difficult”, e.g., hard rock, soils with boulders, or debris, existing foundations, high groundwater.
- There is restricted access and/or limited overhead clearance.
- There are subsurface voids (e.g., karstic limestone).
- Vibrations and noise must be limited.
- Structural settlement must be minimized.
- Relatively high unit loads (e.g., up to 450 K axial for a single pile) are required.

The various micropile types (A, B, C, and D) are defined by the drilling and grouting methods employed during installation (FHWA, 1997). The selection of the micropile type

will typically be left to the discretion of the contractor and dictated by subsurface conditions.

MICROPILE DESIGN

Micropile foundations designed for this project consisted of a varying number of grouped micropiles arranged in circular arrays. The piles are angled away from center and derive their capacity through interaction with the native soils/bedrock. A patented Foundation Schedule was developed for each foundation location, defining the range of probable geotechnical overburden and bond units. Highly trained field personnel employed this data to allow for real-time foundation optimization. Standard Penetration Test (SPT) samples were collected during the drilling of the first pile at a given location. These samples effectively characterized the geotechnical conditions in the overburden material for lateral resistance at various depths, and continued characterization into the bond unit. In combination with the Foundation Schedule, these SPT values and field observation of geotechnical material enabled the piles to be site-specifically optimized, determining both the quantity of piles, as well as the lengths of cased and uncased sections.

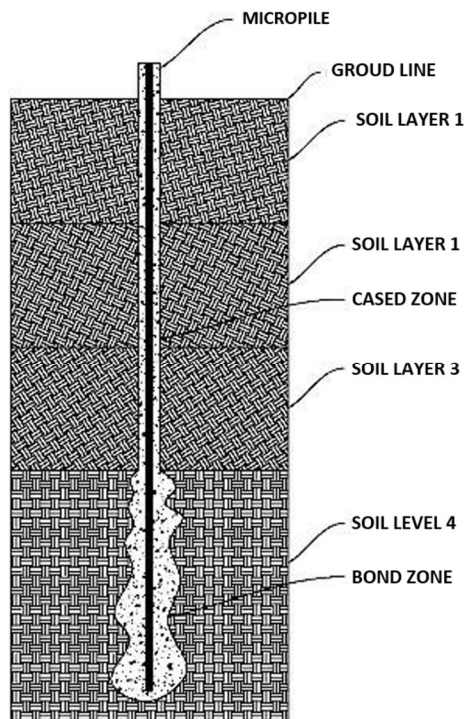

Figure 4: Micropile Installation Schematic

The initial geotechnical report for the alignment did not provide boring data at every structure site, leaving some uncertainty on the depth to bedrock as design commenced. The anticipated geotechnical conditions are summarized in Table 1, and consisted of weak cohesive soils over bedrock at variable depths of approximately 50 feet to 110 feet below ground surface.

Table 1: Expected Geotechnical Conditions

Layer	Depth (ft)	Soil Type	Average N-Value	Recommended Soil Properties					
				Effective Friction Angle (ϕ') (degrees)	Effective Cohesion (c') (psf)	Undrained Shear Strength (S_u) (psf)	Total Unit Weight (γ_t) (pcf)	Material Stiffness E (ksi)	Strength Reduction Factor (α)
1	0-5.5	Soft peat and organic silt	0	0	0	250	100	NA	1.10
2	5.5-40	Stiff silty clay	14	0	0	940*	125	0.6**	0.75
3	40-51	Very stiff to hard clayey silt	30	30	100***	0	130	2.1**	1.00
4	51-65	Very dense gravel and silty sand	100+	36	0	0	135	10+**	1.00

* Soils generally vary from stiff to very stiff. Cohesion values for unconfined compression tests in the Troy Meadows area varied from about 750 psf to 1190 psf, for an average value of approximately 940 psf.

** Based on blow count and/or unconfined compression test correlations with published data.

*** Recommended soil parameters assume these glacial soils behave as granular materials.

VALUE ENGINEERING AND DESIGN

Prior to foundation construction, two rounds of value engineering were completed, effectively decreasing the number of micropiles and total disturbance area of the concrete caps. The first round of value engineering investigated altering the original conceptual foundation design supplied by the contractor, which included larger diameter micropiles utilizing a bolted steel pile cap. The original steel cap was segmented and intended to be field-assembled on the micropile array into a larger cap. While steel pile caps can provide many benefits to project cost and schedule, the magnitude of tower loads and challenging geotechnical conditions within Troy Meadows were not conducive to an economical steel cap design. Changing the cap material from steel to concrete improved the fixity between the piles and cap, and eliminated the field fit-up associated with the bolted steel cap. The revision to the cap design led to a reduction in micropile casing diameter and a more efficient layout of individual micropiles.

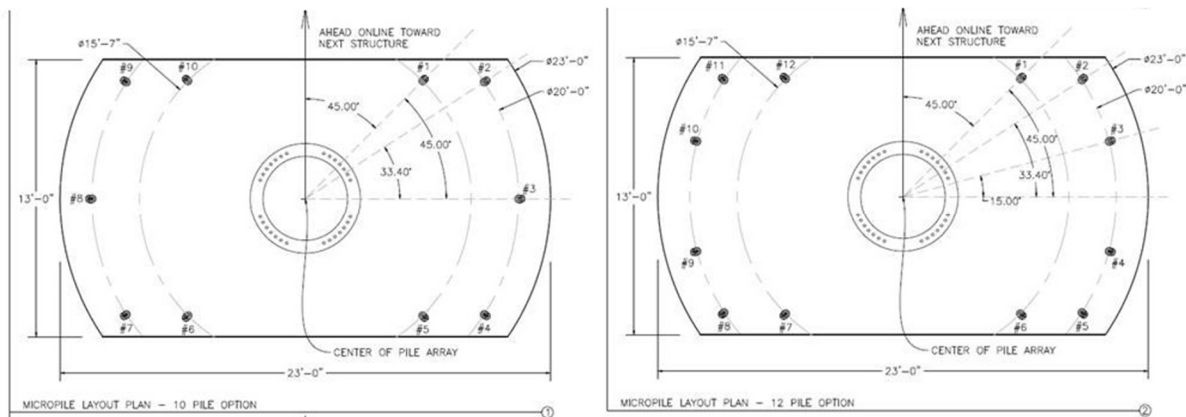

Figure 5: Value Engineered Concrete Cap Design

The second round of value engineering analyzed the use of site-specific directional structure loading. The use of directional loading components and individual load combinations allowed the foundation design team to reduce the size of the concrete pile cap, decreasing the total permanent disturbance area. The revised concrete cap design is shown in Figure 3.

Micropiles and pile caps were designed to satisfy strength requirements by utilizing the maximum bi-directional structure reactions applied longitudinally and transversally to the foundations. The reactions were provided by the pole manufacturer and listed as a group of individual load combinations. All load combinations were individually considered to ensure an economical design could be achieved. Representative tower loads are shown in Table 2.

Table 2: Tower Reactions with Overload Factor

Structure Number	Tower Type	Load Case	GROUP Design Load Case	Design Loads				
				Trans Shear (kip)	Long Shear (kip)	Axial (kip)	Trans Moment (kip-ft)	Long Moment (kip-ft)
82/3	160'	NESC Extreme Wind	Transverse	147.725	0	198.84	14381.675	8.15
		Bound Cond TR	Longitudinal	32.6625	56.6125	379.21	3208.275	9185.75
81/6, 82/4	175'	NESC Extreme Wind	Transverse	150.0375	0	203.55	15969.0875	8.775
		Bound Cond TL	Longitudinal	33.0125	56.75	387.81	3589.0125	9882.5125
81/5	190'	NESC Extreme Wind	Transverse	154.4375	0	214.75	18412.0625	11.325
		Bound Cond TL	Longitudinal	33.55	56.7875	407.71	4169.475	10940.975
81/4, 82/1, 82/2	195'	NESC Extreme Wind	Transverse	155.925	0	218.13	19250.9875	12.0375
		Bound Cond TL	Longitudinal	33.7375	56.7875	413.68	4370.5875	11307.2625

The micropile analysis subjects pile groups to vertical, lateral, and overturning loads in a three-dimensional model for the proposed pile group geometry. The pile head condition can be modeled as fixed, pinned, or elastically restrained by the pile cap, depending upon the type of connection detail utilized between the piles and the cap. The designer defines the nonlinear response of the soil in the form of t-z and q-w curves for axial loading, t-θ curves for torsional loading, and p-y curves for lateral loading in flat ground conditions. The final solution requires several iterations to accommodate the nonlinear response of each of the piles, resulting in load re-distribution amongst the pile group. Following numerous design iterations, a final micropile solution for each soil or rock unit is chosen. This analysis identifies the individual pile loads (axial, shear, and moment) and the maximum internal stress in each pile. By analyzing this data along the length of each pile, the depth-to-fixity of the pile casing (the depth below which the casing is no longer needed to resist lateral loading) is determined. Vertical, lateral, and rotational foundation deflections must also be reviewed and compared to structure performance requirements. The number of micropiles, casing size, and minimum casing embedment were selected for each foundation option to efficiently satisfy loading and deflection criteria, and were summarized in the Foundation Schedule for each structure.

The geotechnical report included soil corrosivity tests at several micropile foundation locations, which indicated that aggressive soils would be encountered. The designer conservatively chose to follow a corrosion resistance method which used a sacrificial steel thickness of 4 millimeters applied to the radius of the casing for a 75 year design life in accordance with recommendations in FHWA SA-97-070.

The structural concrete pile cap was designed in accordance with American Concrete Institute (ACI) standards using Load and Resistance Factor Design (LRFD) methodology. Embedded steel elements in the concrete pile cap were designed in accordance with the current edition of the Steel Construction Manual published by the American Institute of Steel Construction, Inc. (AISC), using LRFD. The Micropiles were designed using the methods of FHWA Micropile Design and Construction Guidelines (FHWA 2000), in combination with LRFD methodology per AISC and ACI. Figure 3 illustrates the bi-directional layout of the micropile groups for varying pile quantities determined by the field characterization method. The anchor bolts for the transmission pole were developed in the concrete cap through the use of termination plates and additional shear, as shown in Figure 5.

FOUNDATION CONSTRUCTION

Once it was determined that helicopter support and micropile foundations would be employed, individual activities needed to be scheduled within a condensed project time frame. The construction schedule for this section of the project was restricted by an electrical outage schedule governed by numerous factors. An active bald eagle nest located in close proximity to the ROW further limited construction within the wetland habitat to a 106 day window, with just 60 days allotted for foundation work.

Lightweight, componentized drill rigs were utilized, providing for efficient helicopter transport. In addition to the aforementioned access constraints, foundation challenges included limited geotechnical data; drilling spoils containment with the presence of standing surface water; concrete placement within a protected habitat; and installing heavily loaded structures in deep, soft soils. Geotechnical reports suggested rock at depths ranging from 80 to 120 feet, but exact depths were unknown.

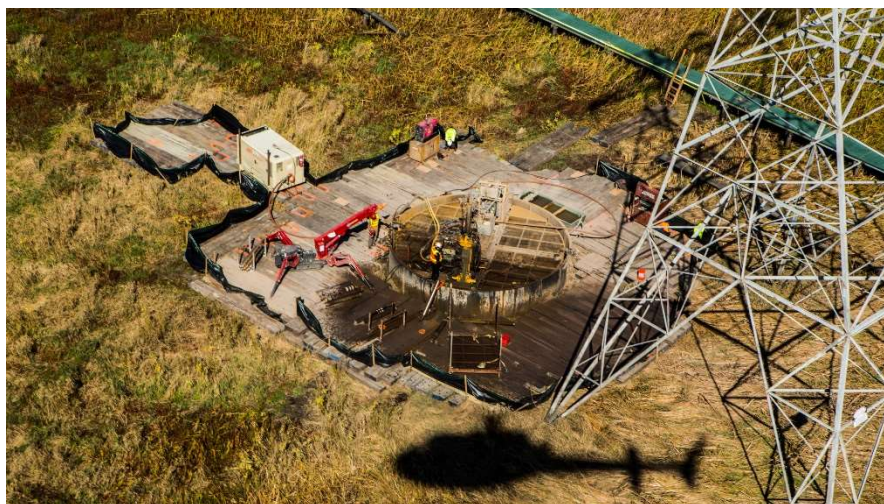

Figure 6: Minimized Drill Site Footprint

The ambiguity in depth to rock and rock quality prior to installation necessitated designs be developed for both Type A and Type B micropiles. Type A micropiles are gravity-grouted piles installed in rock or other consolidated material. Type B refers to low-

pressure-grouted micropiles installed in unconsolidated materials. Pressures for a Type B micropile typically range between 20-200 psi, and neat cement grout is injected into the drilled hole as temporary steel drill casing or auger is withdrawn. The developed Foundation Schedule was employed to determine the grouting method and adapt the pile design to actual geotechnical conditions at the time of installation. Geological characterization was completed during the drilling of the first pile at each foundation location, effectively determining the pile type, quantity and depth for each structure. The accelerated project schedule did not allow for delays associated with redesign, and the ability to employ predetermined solutions removed much of the risk associated with limited geotechnical data.

A unique closed cell cofferdam setup was employed at each site to reduce construction impacts to the wetland. The setup, illustrated in Figure 7, consisted of curved steel sheets, weighing approximately 2,000 pounds. The sheets were driven into the ground to provide a stable platform for equipment in soft soils and groundwater, contain drill cuttings and fluids from entering the wetland, and act as a form for concrete placement during micropile cap construction. Cofferdams were constructed utilizing helicopter portable cranes and small excavators set onto local areas of crane matting. The use of this equipment significantly reduced helicopter hours, contributing toward schedule compliance and control of overall project costs. A rotating drill carriage and micropile drill were set on the cofferdam and used to install micropiles in an array of vertical and battered piles.



Figure 7: Drill Site Setup

During drilling operations, the portable cranes were used to handle casing and drill rods, which were staged on temporary crane mats. The cranes fed the drill as piles were installed to depths ranging from 90 to 150 feet. The cranes also served to place micropile testing equipment during the proof test program at each foundation.

Following micropile installation, the drill and drill carriage were removed from the site to allow for cuttings removal, tying of rebar and form construction. A pre-constructed anchor bolt cage was flown to the site and supported by the cofferdam, and concrete was cast

from crane-type concrete buckets. A high early concrete design was chosen to accelerate sufficient strength for form removal, allowing poles to be set less than one week following placement.



Figure 8: Completed Concrete Cap

CONCLUSION

The use of micropile foundations and helicopter portable tubular steel poles allowed the project team to meet an aggressive construction schedule within the Troy Meadows wetland. Foundation work was completed ahead of schedule and all seven monopoles were erected in just three days.

Innovative design and construction methods allowed for work to be completed with minimal impacts to the protected habitat. Accessing foundation sites by helicopter eliminated the significant risk associated with installing and managing matted access roads and matted work areas. This also reduced the total impact to the wetland. The use of the closed cell cofferdams allowed foundation crews to contain drill cuttings and fluids, and created a minimal area of impact from drilling activities.

The 500 kV Troy Meadows segment went into service on April 1, 2014.

REFERENCES

American Concrete Institute (ACI). (2008). "Building Code Requirements for Structural Concrete" (ACI 318-08) and Commentary, *American Concrete Institute (ACI) Committee 318*, publication no. 318-08.

American Institute of Steel Construction (AISC). (2008). *Steel Construction Manual. 13th edition*.

Armour, T, Groneck, P, Keeley, J & Sharma, S (2000). "Micropile Design and Construction Guidelines Implementation Manual." *Report no. FHWA-SA-97-070*.

Armour, T, Groneck, P, Keeley, J, Sabatini, PJ, Tanyu, B (2005). "Micropile Design and Construction Reference Manual." *Report no. FHWA-NHI-05-039*.

GROUP. Computer software. <http://www.ensoftinc.com/>. Vers. 2013. Ensoft, Inc.

Reese, L. C., and Van Impe, W. F. (2001). "Single Piles and Pile Groups Under Lateral Loading." A. A, Balkema, Rotterdam, Netherlands.